

NOTE:

All activating devices (push plates, card readers, motion sensors, ect...) must connect to the TDM. Purple wires from both OC-904 controls connect in parallel. Be sure to observe polarity of the purple wires (+to+, -to-).

NOTE: Mag lock with N.C. contact shown. Other locks may require N.O. contact

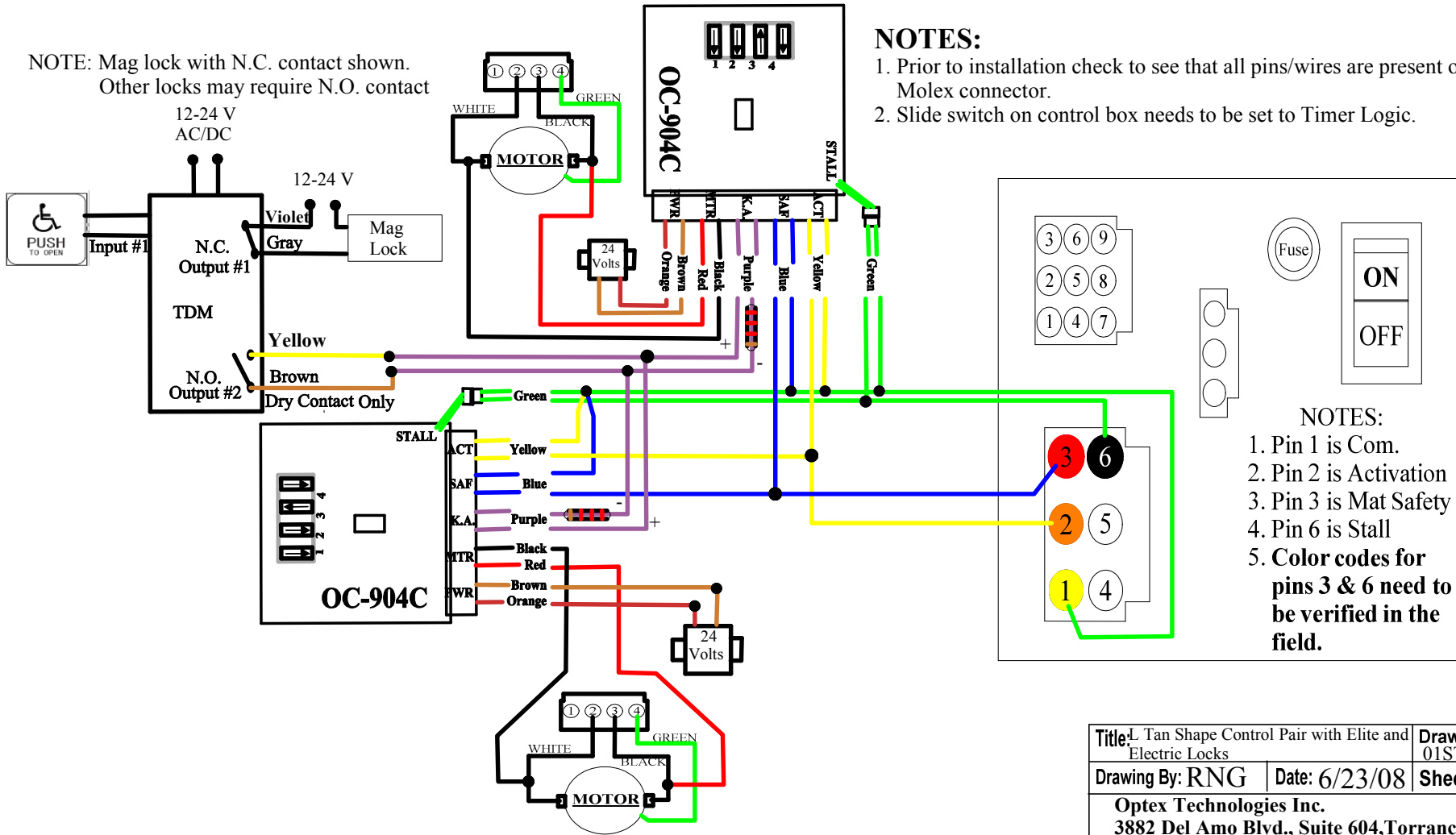

INSTALLATION NOTES:

1. Set door speeds and verify proper door operation prior to final connection of sensor system.
2. Technician **MUST WALK TEST** to verify function and detection patterns comply with ANSI/BHMA A156.10 requirements.

NOTES:

1. Prior to installation check to see that all pins/wires are present on the six pin Molex connector.
2. Slide switch on control box needs to be set to Timer Logic.

NOTES:

1. Pin 1 is Com.
2. Pin 2 is Activation
3. Pin 3 is Mat Safety
4. Pin 6 is Stall
5. Color codes for pins 3 & 6 need to be verified in the field.

Title: L Tan Shape Control Pair with Elite and Electric Locks		Drawing # 01STALELI03
Drawing By: RNG	Date: 6/23/08	Sheet: 1 of 1
Optex Technologies Inc. 3882 Del Amo Blvd., Suite 604, Torrance, CA 90503 Office: (800)877-6656, Fax: (310)214-8655		